



AVK EXTENSION SPINDLE, TELESCOPIC

04/07

For service connection valves, key adaptor #14-22

001

AVK telescopic extension spindles are designed for ease of use and long service life. The two fixation lugs can be attached to AVK surface boxes, a lock spring prevents the telescopic part from collapsing during installation, and a defrosting hole enables insertion of a heating element. The extension spindles are made of corrosion-free materials and the centre sleeve and bottom cover protect against penetration of impurities.

Product Description:

Extension spindle for service connection valves - Telescopic - key adaptor #14-22 - L8=Actual length for water, neutral liquids and gas

Standards:

- Designed to all standards

Features:

- The conical key adaptor fits most standard T-keys
- The top adaptor has a defrosting hole intended for insertion of a heating element to prevent freezing of ground water inside
- The two fixation lugs can be attached to AVK surface boxes and support tiles
- A lock spring prevents the telescopic part from collapsing during installation, as it creates friction inside the inner square tube
- The center sleeve protects against penetration of impurities between the two outer PE pipes
- The inner tube is press fit to the top spanner and bottom adaptor to safeguard the galvanization of the tube
- The bottom cover protects the valve spindle from sand and dirt and enables it to rotate freely
- Patented and fast "Safe-click" mounting by fixing the spindle adaptor to the valve stem with a split and turning the bottom adaptor until a "click" indicates fixation to the valve bonnet
- Available in 5 different lengths



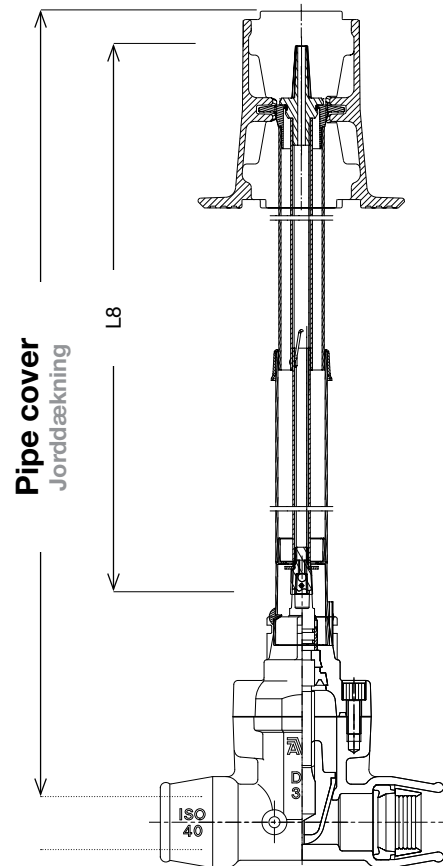
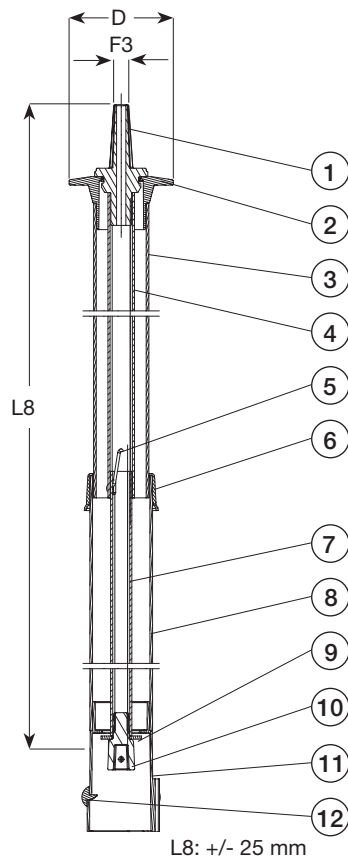

Component List:

1. Key adaptor	Cast stainless steel	2. Top adaptor	PE
3. Protection tube	PE	4. Upper inner tube	Galvanized steel
5. Lock spring	Stainless steel	6. Centre sleeve	Plastic
7. Lower inner tube	Galvanized steel	8. Lower protection tube	PE
9. Stop ring	PE	10. Spindle adaptor	Cast stainless steel
11. Bottom cover	PE	12. Click ring	PE

Components may be substituted with equivalent or higher class materials without prior notification.

Reference Nos. and Dimensions:

AVK ref. nos	DN/DN mm	L8 mm	Pipe cover mm	D mm	F3 mm	Theoretic. weight kg
04-032-2-0001	25 - 50	450 - 700	700 - 920	98	14 - 22	1.9
04-032-2-0501	25 - 50	650 - 1100	900 - 1320	98	14 - 22	2.5
04-032-2-1001	25 - 50	1050 - 1750	1300 - 1970	98	14 - 22	3.7
04-032-2-1101	25 - 50	900 - 1500	1150 - 1720	98	14 - 22	2.5
04-032-2-1201	25 - 50	1400 - 2350	1650 - 2570	98	14 - 22	4.7
04-032-2-1501	25 - 50	1700 - 2900	1950 - 3120	98	14 - 22	5.4