



AVK COMBI-CROSS, FLANGED, 3 OUTLETS, PN10/16

18/80-003

Ball valves and flanged DN100 center outlet, DN100-300



AVK gate valves are designed with built-in safety in every detail. The wedge is fully vulcanized with AVK's own drinking water approved EPDM rubber compound. It features an outstanding durability due to the ability of the rubber to regain its original shape, the double bonding vulcanization process and the sturdy wedge design. The triple safety stem sealing system, the high strength stem and the thorough corrosion protection safeguard the unmatched reliability.



Product description:

Combi-cross 3 outlets with ball valves and flanged DN100 center outlet. For drinking water and neutral liquids to max. 70°C

Standards:

- Designed according to EN 1074 part 1 & 2, Designed according to EN 1171
- Standard flange drilling to EN1092-2 (ISO 7005-2), PN 10/16

Test/Approvals:

- Hydraulic test according to EN 1074-1 and 2 / EN 12266.
- Seat: 1.1 x PN (in bar), Body: 1.5 x PN (in bar). Operation torque test.
- Approved according to ÖVGW Certificate W 1.417



Features:

- Fixed, integral wedge nut prevents vibration and ensures durability
- Wedge fully vulcanized with drinking water approved EPDM rubber and equipped with wedge shoes to provide smooth operation
- Large conical stem hole in the wedge prevents stagnant water
- Wedge and body guide rails ensure stable operation
- Stainless steel stem with wedge stop and rolled threads for high strength
- Full circle thrust collar provides fixation of the stem and low free running torques
- Triple safety stem sealing with an NBR wiper ring, a polyamide bearing with four NBR O-rings and an EPDM rubber manchette
- Round EPDM bonnet gasket fixed in a recess
- Countersunk and sealed stainless steel bonnet bolts encircled by the bonnet gasket
- Full bore
- Low operating torque
- Fusion bonded epoxy coating to DIN 30677-2, GSK approved
- The center outlet allows easy insertion of a cleaning pig
- All flanges are free flanges without need for stud bolts
- The face to face dimensions are kept to a minimum for convenient installation in chambers
- The valves are prepared for/delivered with ball valves making it possible to take out water samples or to supply auxiliary water

Accessories:

Extension piece, blind flange for center outlet, stem cap, handwheel, extension spindle, flange adaptor and combi-flange

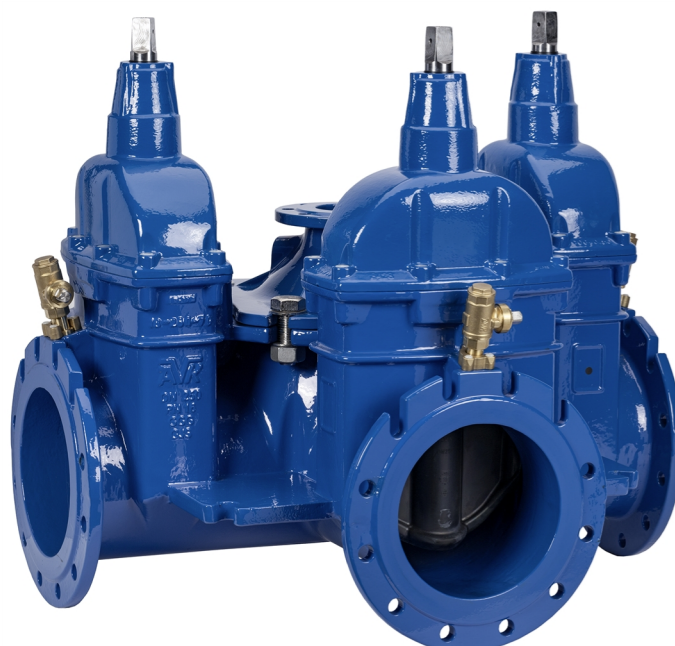

Expect ... **AVR**

The designs, materials and specifications shown are subject to change without notice due to the continuous development of our product programme.

AVK COMBI-CROSS, FLANGED, 3 OUTLETS, PN10/16

18/80-003

Ball valves and flanged DN100 center outlet, DN100-300

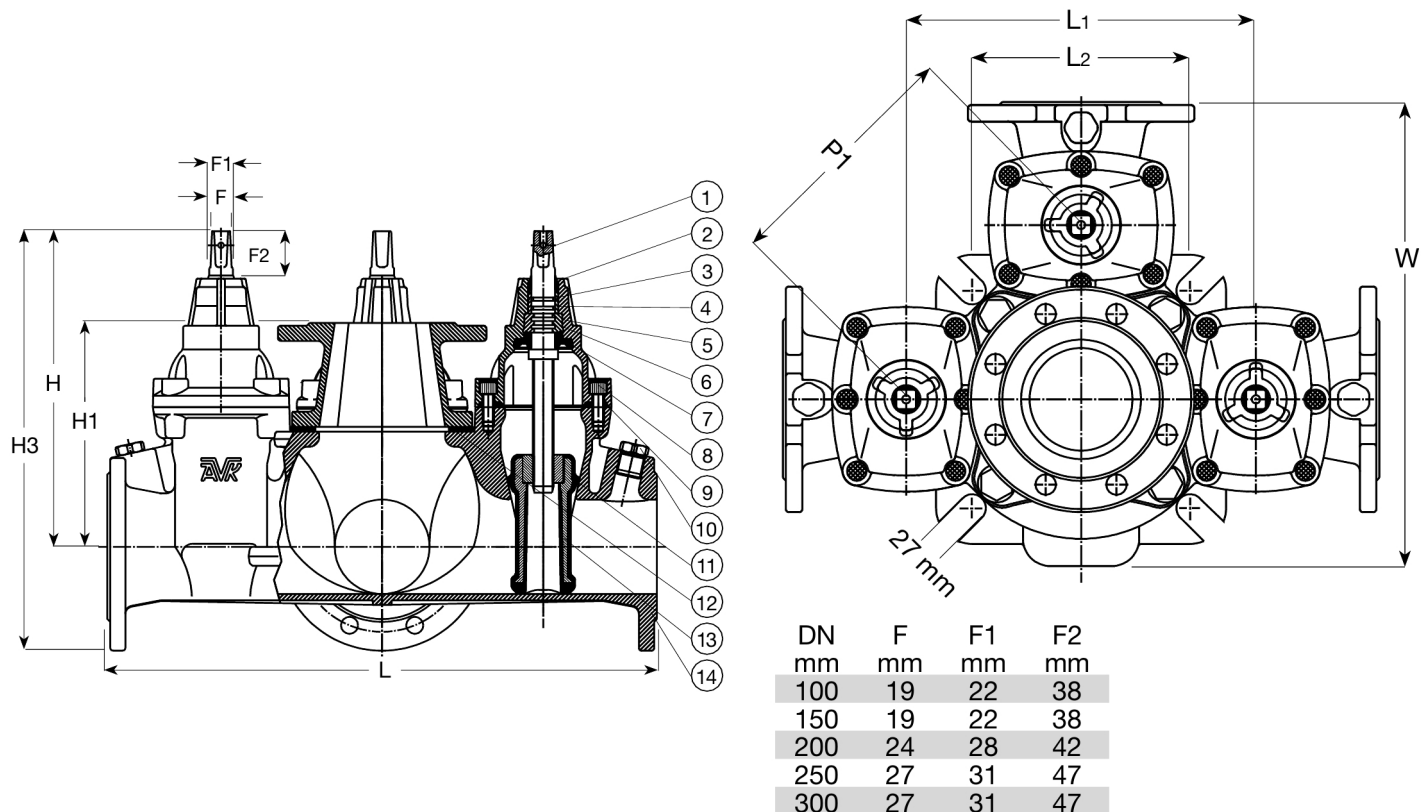

Component list:

1. Stem	Stainless steel 1.4104 (430F)	8. Bonnet bolt	Stainless steel A2, sealed with hot melt
2. Wiper ring	NBR rubber	9. Bonnet gasket	EPDM rubber
3. O-ring	NBR rubber	10. Outlet for service valve	Brass, DZR
4. Bearing	Polyamide	11. Wedge nut	Brass, DZR CW626N
5. Bonnet	Ductile iron GJS-500-7 (GGG-50)	12. Center outlet gasket	EPDM rubber
6. Thrust collar	Brass, DZR CW602N	13. Wedge	Ductile iron, EPDM encapsulated
7. Manchette	EPDM rubber	14. Body	Ductile iron GJS-500-7 (GGG-50)

Components may be substituted with equivalent or higher class materials without prior notification.

Reference nos. and dimensions:

AVK ref. no.	DN	Flange	L	L1	L2	W	H	H1	H3	P1	Theoretical weight / kg
	mm	drilling	mm	mm	mm	mm	mm	mm	mm	mm	
18-100-80-011	100	PN10/16	580	340	312	453	305	237	415	240	90
18-150-80-011	150	PN10/16	620	372	360	460	452	298	595	263	165
18-200-80-001	200	PN10	750	468	445	544	596	370	766	331	280
18-200-80-011	200	PN16	750	468	445	544	596	370	766	331	280
18-250-80-006	250	PN10	960	656	617	760	664	375	864	464	450
18-250-80-016	250	PN16	960	656	617	760	664	375	864	464	450
18-300-80-006	300	PN10	1050	702	617	845	740	480	968	496	620
18-300-80-016	300	PN16	1050	702	617	845	740	480	968	496	620

The designs, materials and specifications shown are subject to change without notice due to the continuous development of our product programme.